

Frost Protected Shallow Foundations

Jay H. Crandell, P.E.
ARES Consulting/ABTG

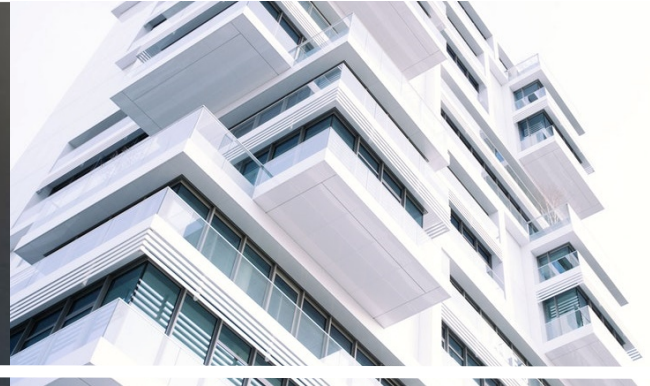

[Applied Building Technology Group \(ABTG\)](#) is committed to using sound science and generally accepted engineering practice to develop research supporting the reliable design and installation of foam sheathing. ABTG's educational program work with respect to foam sheathing is supported by the [Foam Sheathing Committee \(FSC\)](#) of the [American Chemistry Council](#).

ABTG is a [professional engineering firm](#), an [approved source](#) as defined in [Chapter 2](#) and [independent](#) as defined in [Chapter 17](#) of the IBC.

DISCLAIMER: While reasonable effort has been made to ensure the accuracy of the information presented, the actual design, suitability and use of this information for any particular application is the responsibility of the user. Where used in the design of buildings, the design, suitability and use of this information for any particular building is the responsibility of the Owner or the Owner's authorized agent.

Foam sheathing research reports, code compliance documents, educational programs and best practices can be found at www.continuousinsulation.org.



**Foam Plastic Applications
for Better Building**

Overview

- History & Code Acceptance
- Principles
- Cost Savings
- Technology Verification
- Applications
- Construction Method
- IRC 2006 Requirements
- Plan Review & Inspection Checklist
- Beyond the IRC: ASCE Standard 32-01
- Resources & References
- Conclusions

History of FPSFs

- 1930s – Frank Loyd Wright designed and built the first FPSFs in the Chicago area
- 1950s – 1970s In rebuilding after WWII, Scandinavian countries studied U.S. construction and then became leaders in FPSF technology
- 1980s – U.S. Plastics Industry and NAHB/RC begin technology transfer back to U.S.
- 1992 -1994 U.S. HUD sponsors a 5-home verification study in the northern U.S. climates; Air-freezing Index map is created; U.S. design guide developed
- 1995 CABO OTFDC – first model code recognition of FPSF in U.S.
- 2001 – ASCE standard 32 is completed (based on HUD guides for FPSFs)

Code Acceptance

- 2000/2003/2006 – IRC includes simplified FPSF provisions for homes
- 2003/2006 – ASCE standard 32-01 referenced in IRC and IBC for residential and commercial building applications

Market Acceptance:

- >1,000,000 in Scandinavia (and continuing)
- 1,000s in U.S. (and growing)

Cost & Energy Savings

- Construction cost savings: **\$1,000 to \$4,000**
(depends on size and complexity of foundation and severity of local frost depth/climate)
- Compared to basement construction, the cost savings more than double.
- Annual energy savings: **~\$75 per year**
(typical 6,000 HDD heating climate)
- FPSF insulation amount can be sized to also meet or exceed Energy Code
- FPSF insulation can be increased to improve slab comfort; works great with in-slab heating systems

Aren't these numbers exciting!



TIP: Not necessarily cost-effective for unheated building foundations

Principles

- Frost Depth in Ground
- Heat Transfer & Storage
- Heat Loss at Corners
- Two Approaches, Same Principles
- The “Frost-Heave Triangle”

Frost Depth in Ground

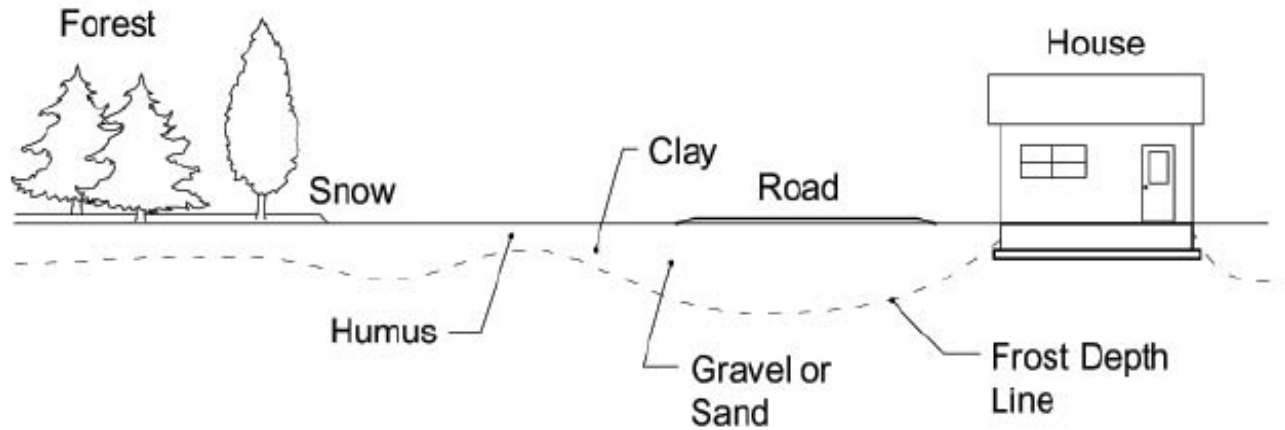

Heat Transfer & Storage

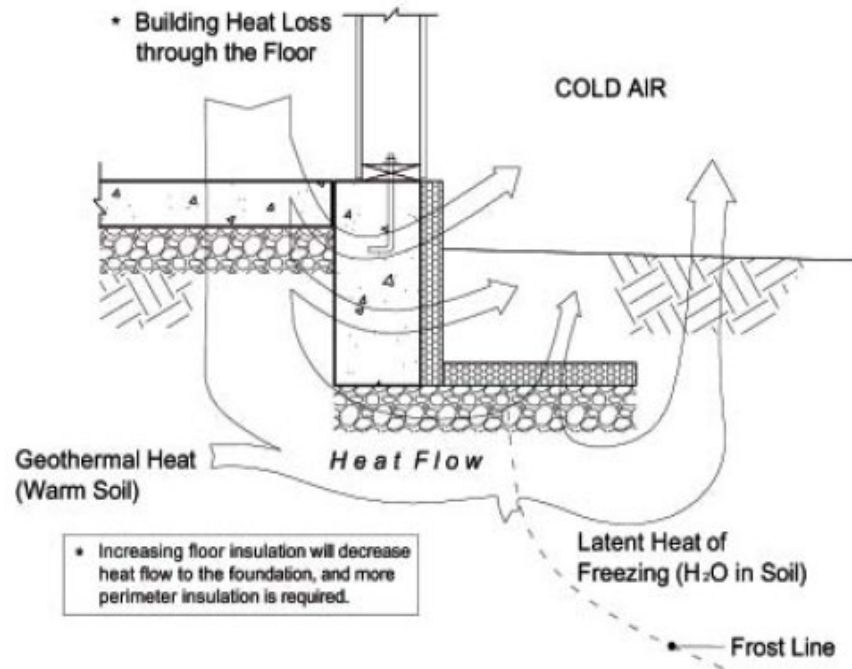

Heat Loss at Corners (3D)

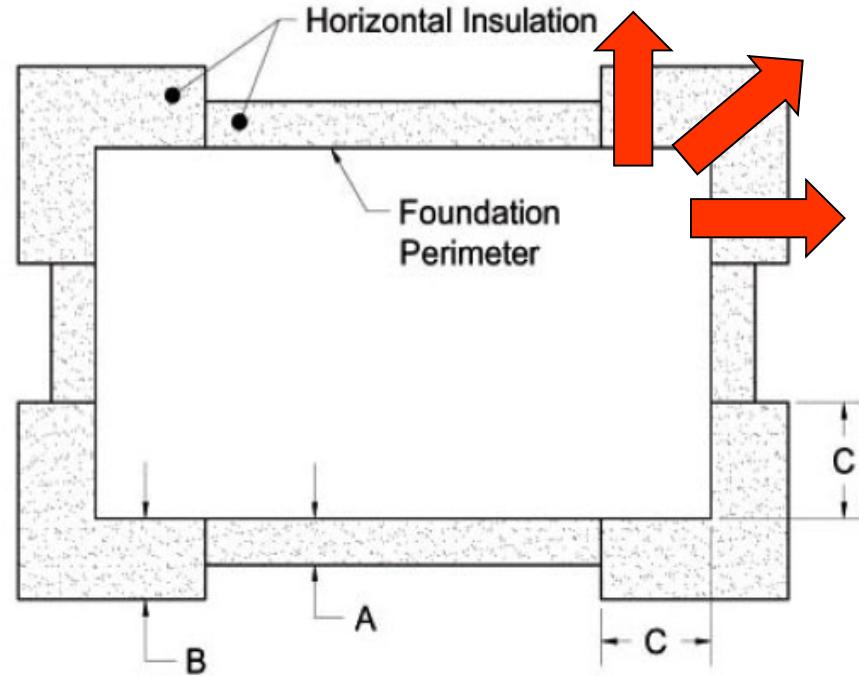

3D heat transfer at outside corners is greater than 2D heat transfer along wall

Two Approaches, Same Principles

- Heated Buildings
(living spaces
conditioned $\geq 64^{\circ}\text{F}$):

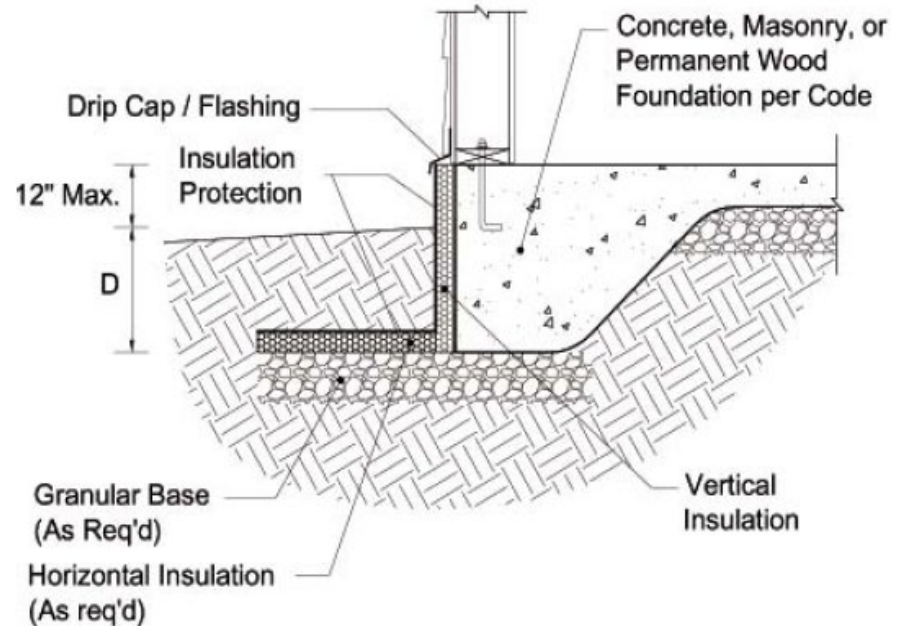

Two Approaches, Same Principles

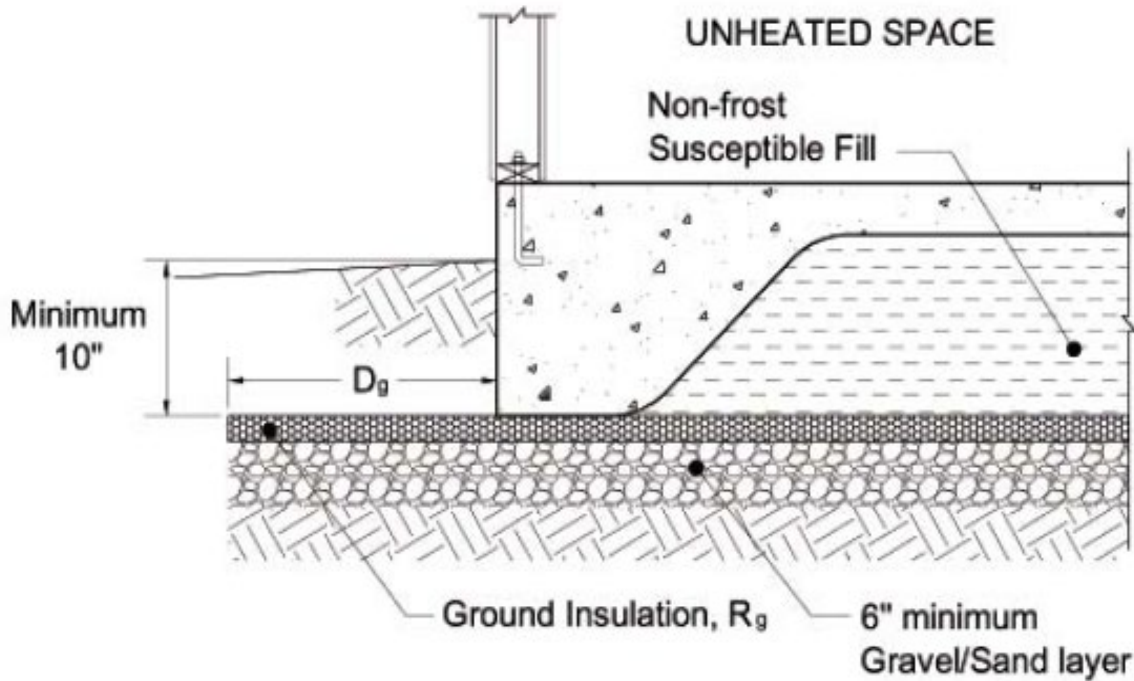

- Unheated Buildings (unconditioned <41oF)

The Frost-Heave Triangle

- All of the following must occur for frost heave to happen:

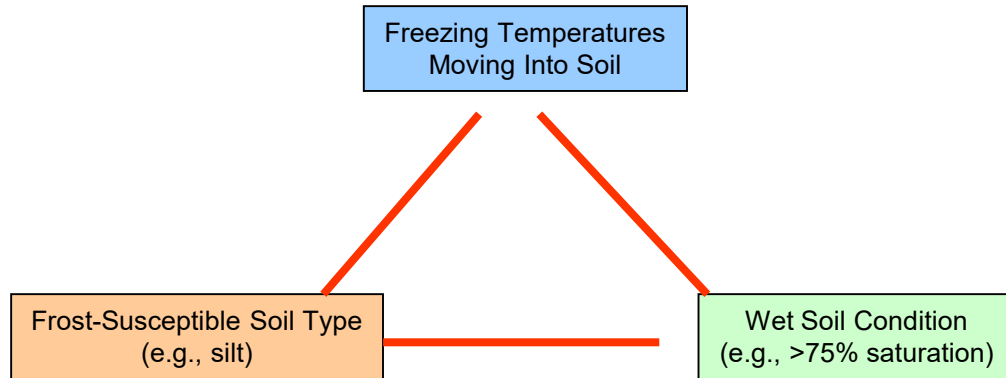

FPSF Technology Verification

- Sponsored by U.S. Dept. of Housing and Urban Development (1992-1995)
- Built and monitored 5 homes in VT, IA, ND, and AK
- Used dataloggers and 90 +/- thermocouples in foundation and ground to monitor temperatures and frost line at building and “far-field”.
- Monitored for 2 complete years and winter events
- Some foundation portions designed for only average winter freezing temperatures to simulate the 100-year event

Test Site #1 – Williston, VT



Test Site #1 - Results

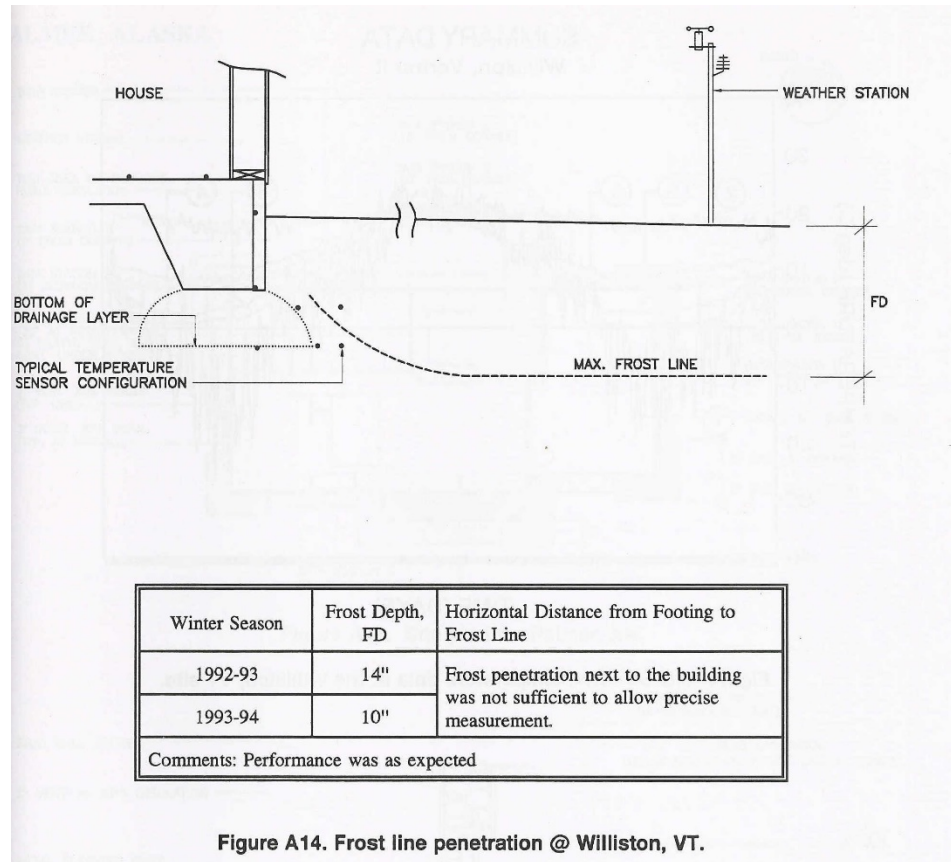

Figure A14. Frost line penetration @ Williston, VT.

Test Site #2 – Spirit Lake, IA



Test Site #2 - Results

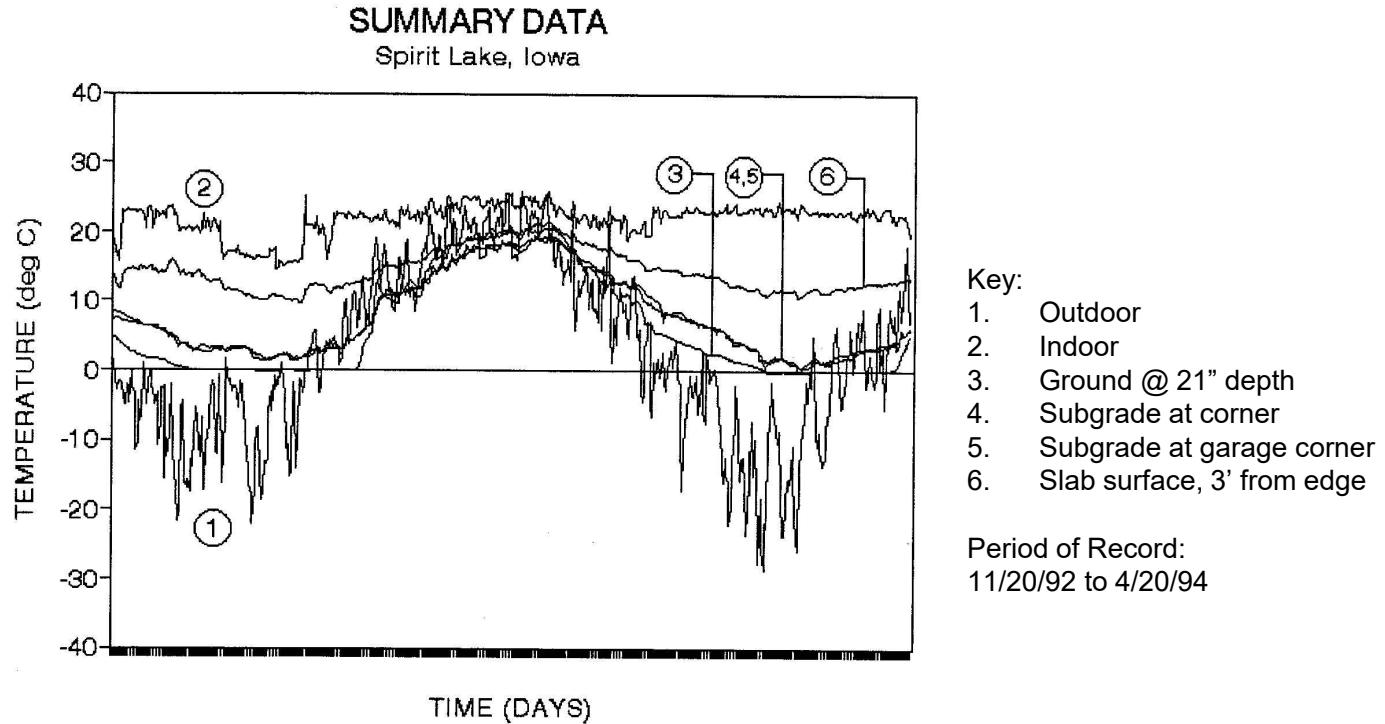

Figure A10. Selected temperature data at the Spirit Lake, IA site.

Test Site #3 – Fargo, ND



Test Site #3 - Results

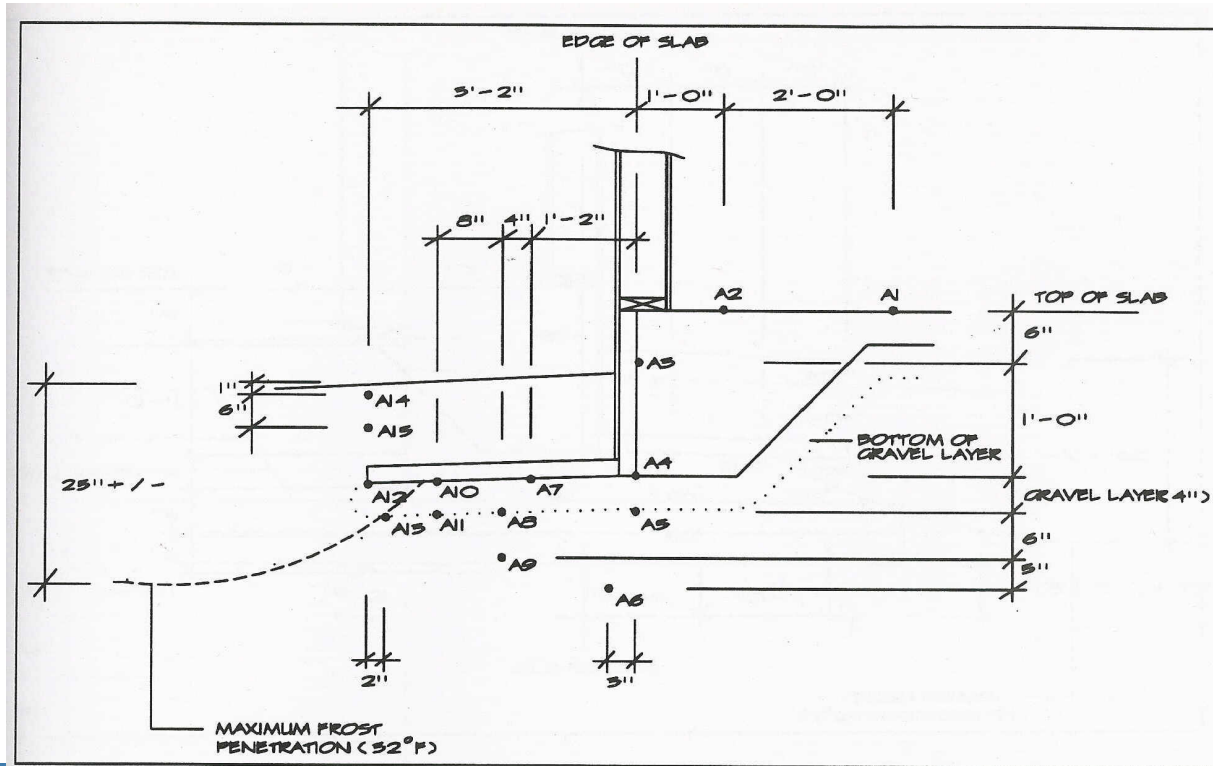
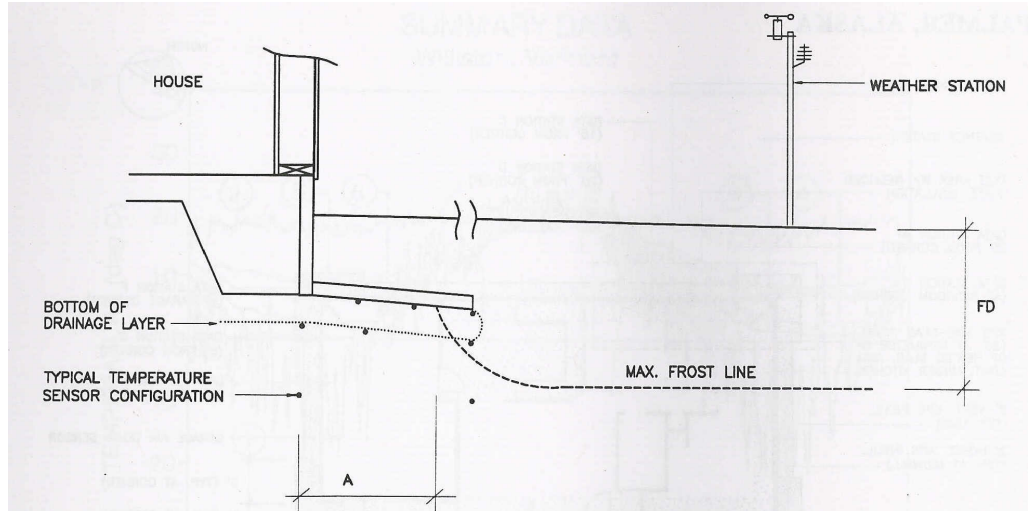

Figure A4. Corner station (A) at Fargo, ND.

Test Site #4 – Palmer, AK



Test Site #4 - Results



Winter Season	Frost Depth, FD	Horizontal Distance from Footing to Frost Line (A)		
		@ Test Corner	@ Test Wall	@Normal Wall
1993-94	26"	15"	20"	24"

Comments: Test corner and test wall regions were purposely designed such that an average winter should have resulted in a frost penetration, A, of approximately 0 inches. Frost penetration at the garage was not sufficient to allow measurement. Performance in both test areas and normally designed areas was as expected.

Figure A18. Frost line penetration @ Palmer, AK.

Test Site #5 – Fargo, ND



Test Site #5 - Results

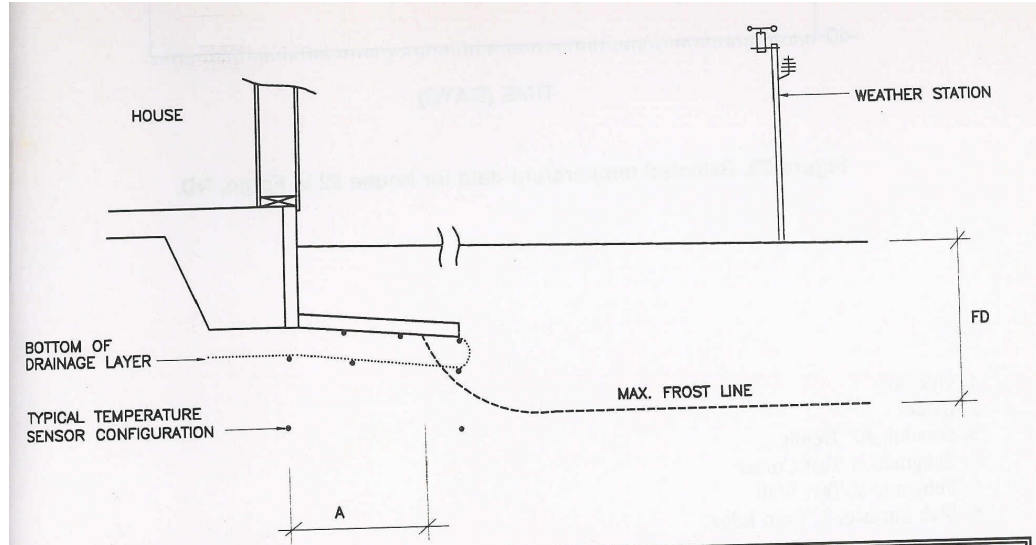

Winter Season	Frost Depth, FD	Horizontal Distance from Footing to Frost Line (A)			
		@ Test Corner	@ Test Wall	Normal Corner	Normal Wall
1993-94	30"	0"	10"	40"	22"

Comments: Test corner and test wall regions were purposely designed such that an average winter should result in a frost penetration, A, of approximately 0 inches. Given the severity of the winter, the test areas and the normally designed regions performed as expected, even at the test wall region where no wing insulation was used.

Figure A22. Frost line penetration for house #2 in Fargo, ND.

Demonstration Projects

- DOE / NREL (House in Colorado)
- DOE Build America (various)
- HUD/PATH Demonstrations (various)
- Others?

FPSF Applications

- Residential Buildings & Additions
- Commercial Buildings
- Infrastructure (U/G utilities, roads, dams, retaining walls, etc.)

Applications: Slab on Ground (Heated Building)*

- Monolithic thickened edge
- Concrete stem wall
- Permanent wood stem wall
- CMU stem wall

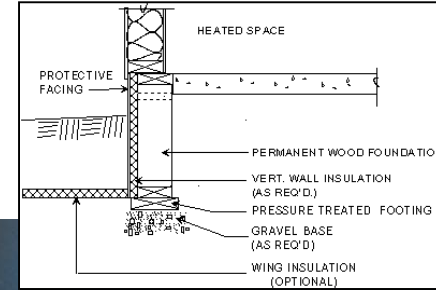
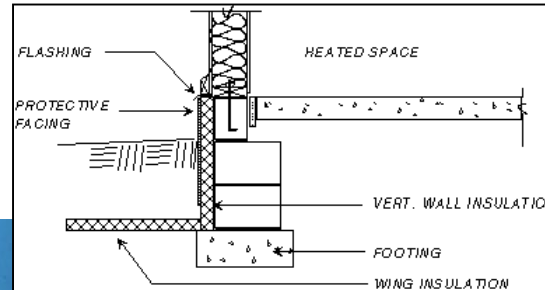
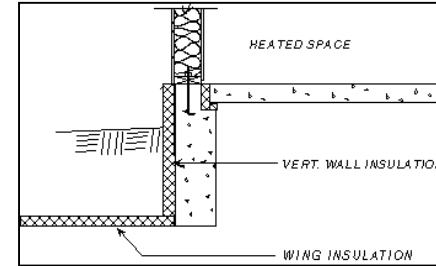
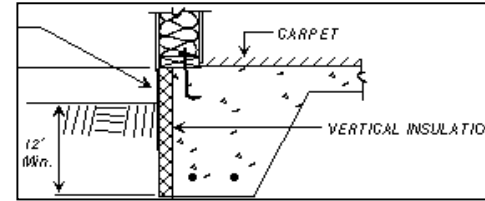

* Recognized in IRC 2000/2003/2006

Applications: Unvented Crawlspace (Heated Building)*

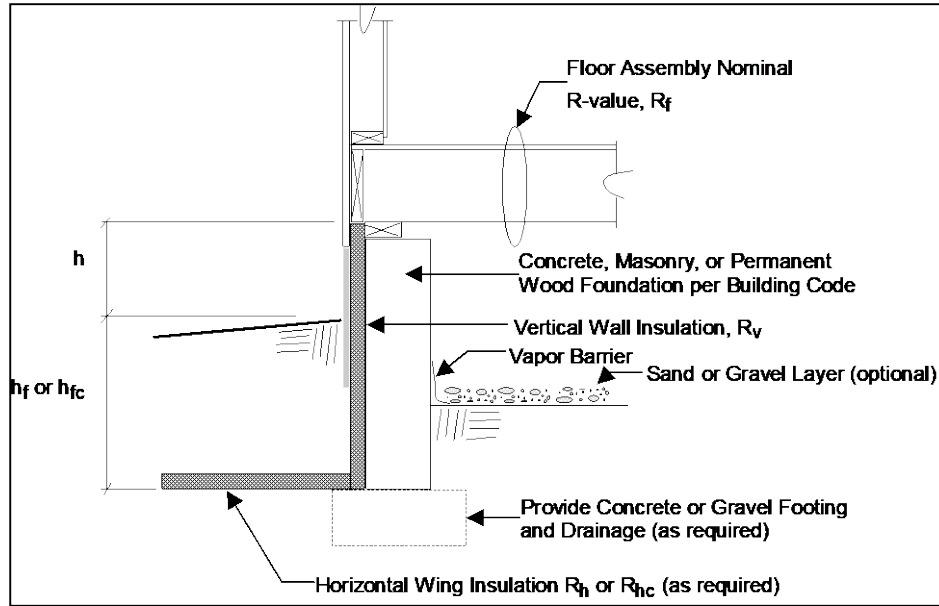

* Unvented crawlspaces recognized in 2006 IRC Section R408.3. But, FPSF insulation must be determined in accordance with ASCE 32-01 (referenced in IRC and IBC)

Applications:

Walk-out Basement (Heated Building)*

- Apply FPSF insulation to exterior of basement wall, or
- Use Permanent wood walls (insulation in wall)

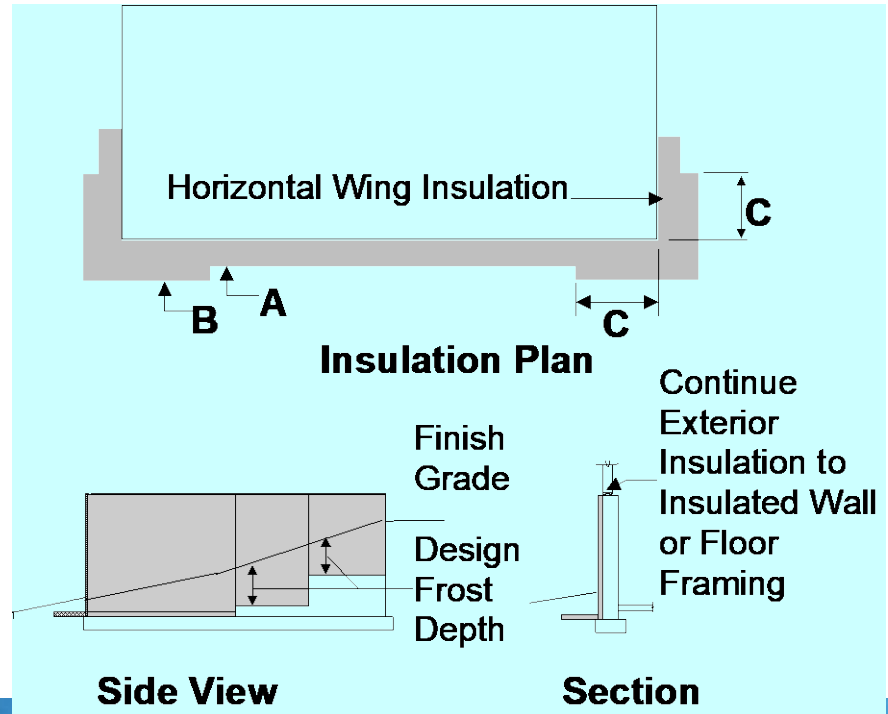

* Not addressed in IRC; must refer to ASCE 32

Applications: Unheated Buildings*

* Must refer to ASCE 32 to size insulation and selection insulation type to support light structural loads

Ground insulation must "blanket" entire footprint of foundation

Also used for unheated portions of heated buildings

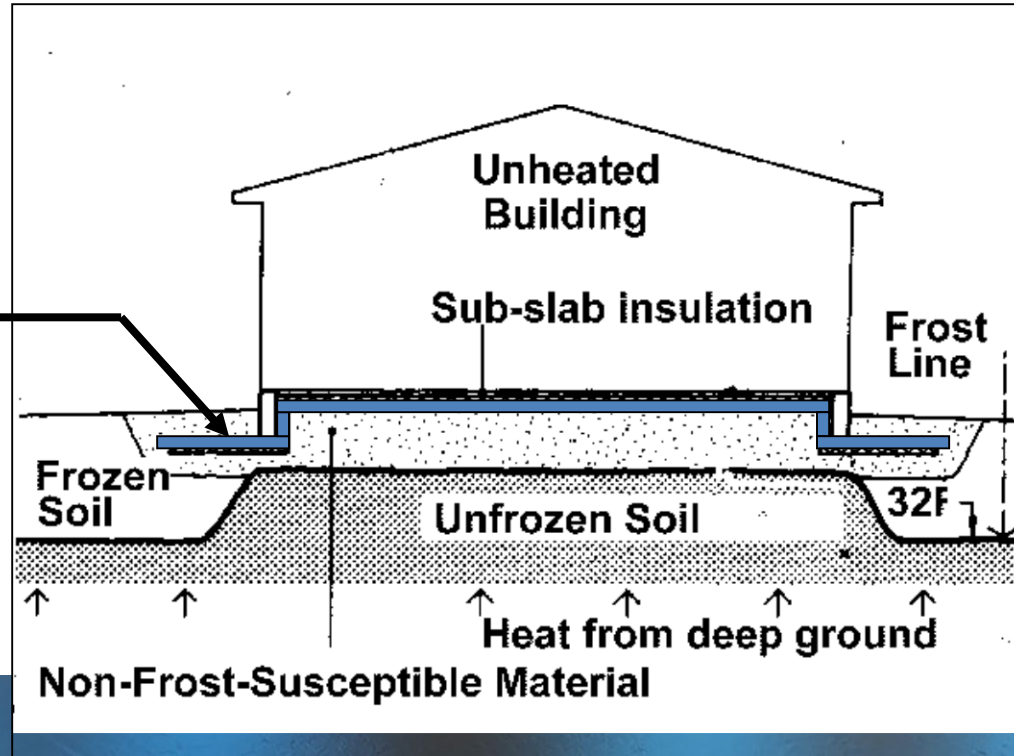

Applications: Unheated “Cold” Foundations*

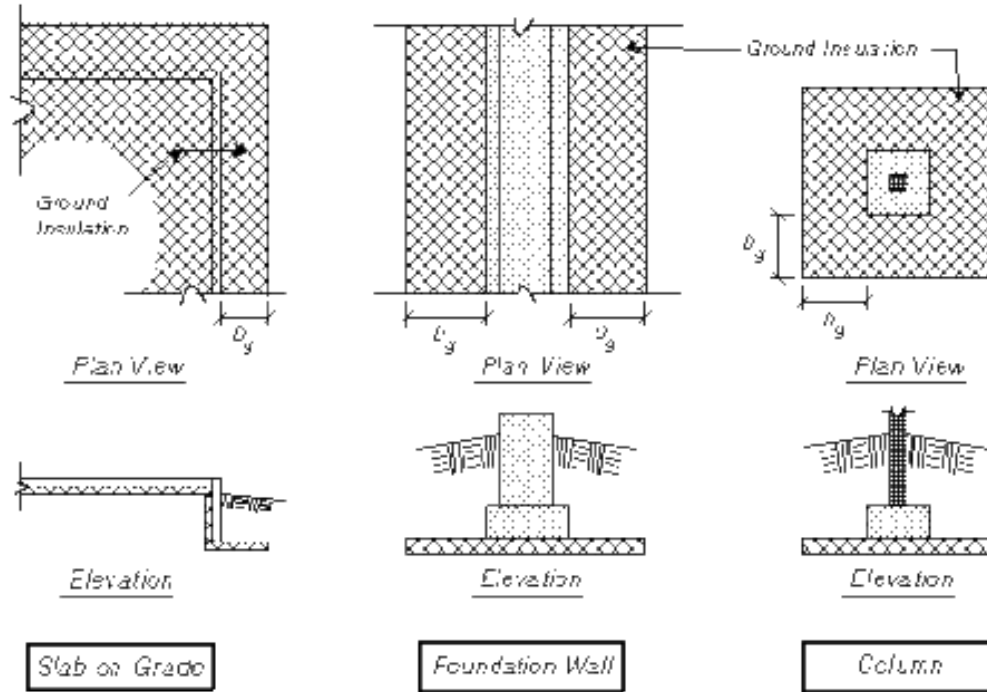

* Refer to ASCE 32
(not addressed in IRC)

Applications:

Exterior Slabs/Stairs, Retaining Walls, U/G Wet Utilities*

*Not addressed in IRC or ASCE
32 – refer to Norwegian guidelines

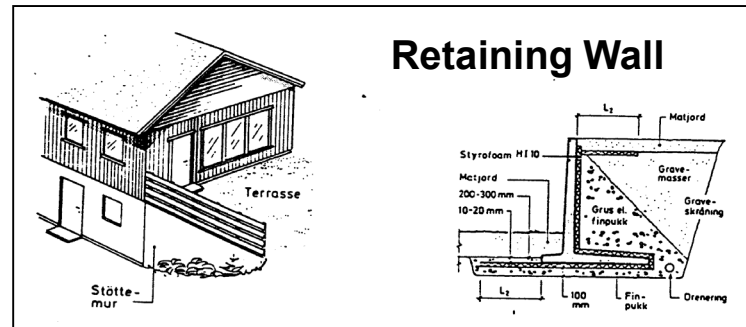
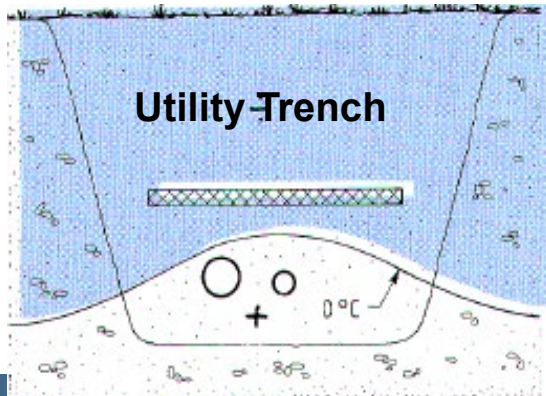
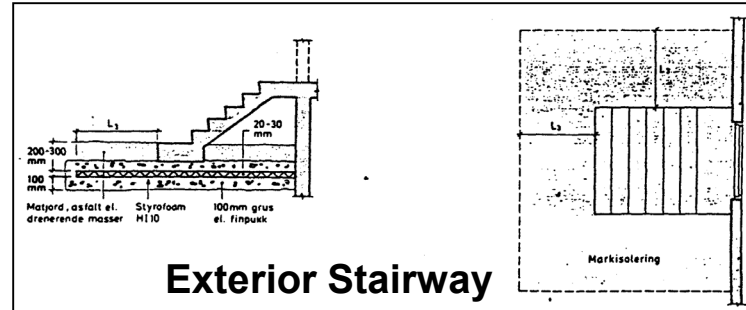

Construction Method (Monolithic S

- Form slab using vertical foam and cast slab
- Place drain pipe (if horizontal insulation used)
- Use concrete truck to place pea-gravel aggregate around foundation
- Place horizontal insulation on smooth gravel surface
- Protect vertical insulation (to 6" below grade)
- Protect horizontal insulation if required and extends more than 24" from face of foundation
- Backfill with loader



Construction Method (Plastic Lumber Stem Wall & SOG)

- Insulation Protection
- Electric Utility Rough-in



2006 IRC Requirements for FPSFs

- SCOPE: heated building slab-on-grade foundations only—for other applications refer to ASCE 32.
- STEP 1: Determine AFI per Figure R403.3(2)
- STEP 2: Specify and size FPSF insulation per Figure R403.3(1) and Table R403.3*
- STEP 3: Details
 - Joining to heated or unheated foundations (R403.3.1)
 - Protection of insulation (R403.3.2)
 - Drainage (R403.3.3)
 - Termite protection (R403.3.4)



*Only XPS and EPS insulation materials listed in Table R403.3(2) and complying with ASTM C578 are permitted for FPSF construction

Example Problem: Lincoln, NE

STEP 1: 100-yr AFI = ~1,500 °F-days

For AFI by local weather stations, refer to
<http://lwf.ncdc.noaa.gov/oa/fpsf>

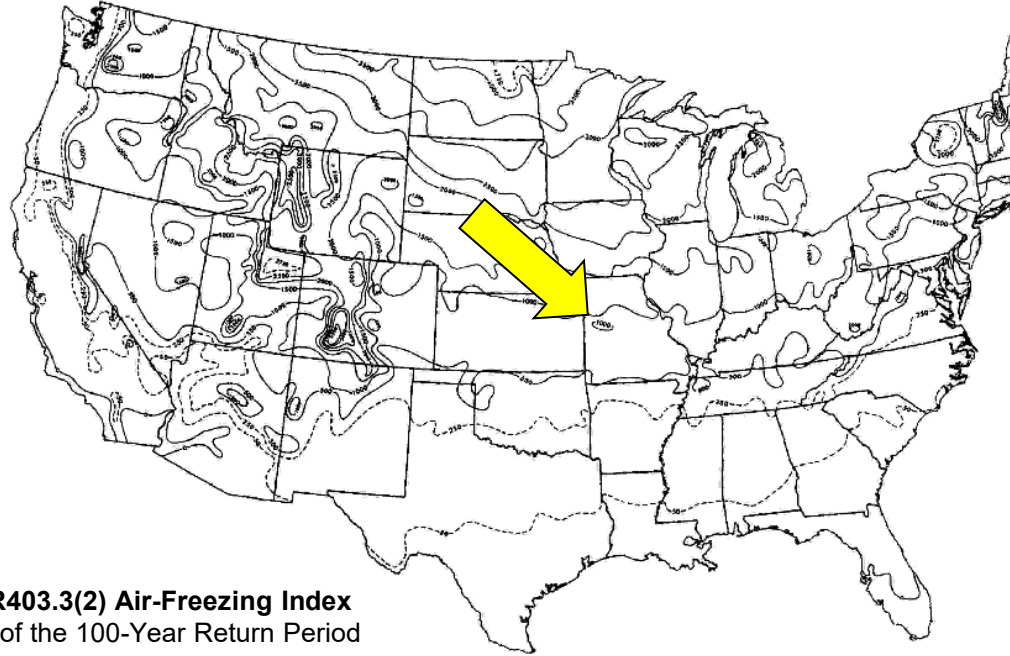

Figure R403.3(2) Air-Freezing Index
Estimate of the 100-Year Return Period

Example Problem: Lincoln, NE

STEP 2: To determine insulation thickness, divide required R-value by effective R-per-inch values (for below ground service) in footnote 'c' of Table R403.2

R-req'd = 4.5

Eff. R/in = 3.2
(Type IX EPS)

Thickness =
 $4.5R / 3.2R/in$
= 1.4" (use 1.5")

Or

Eff. R/in = 4.5
(Type IV XPS)

Thickness =
 $4.5R / 4.5R/in$
= 1.0"

Table R403.3
Minimum Insulation Requirements for Frost-Protected Footings in Heated Buildings

Air Freezing Index (°F ₁₀₀) ²	Vertical Insulation R-Value ^{3,4}	Horizontal Insulation R-Value ^{3,5}		Horizontal Insulation Dimensions per Figure 5. (in inches)		
		Along Walls	At Corners	A	B	C
≤1,500	4.5	NR	NR	NR	NR	NR
2,000	5.6	NR	NR	NR	NR	NR
2,500	6.7	1.7	4.9	12	24	40
3,000	7.8	6.5	8.6	12	24	40
3,500	9.0	8.0	11.2	24	30	60
4,000	10.1	10.5	13.1	24	36	60

Example Problem: Lincoln, NE

STEP 3: Details (Foundation wall cross section)

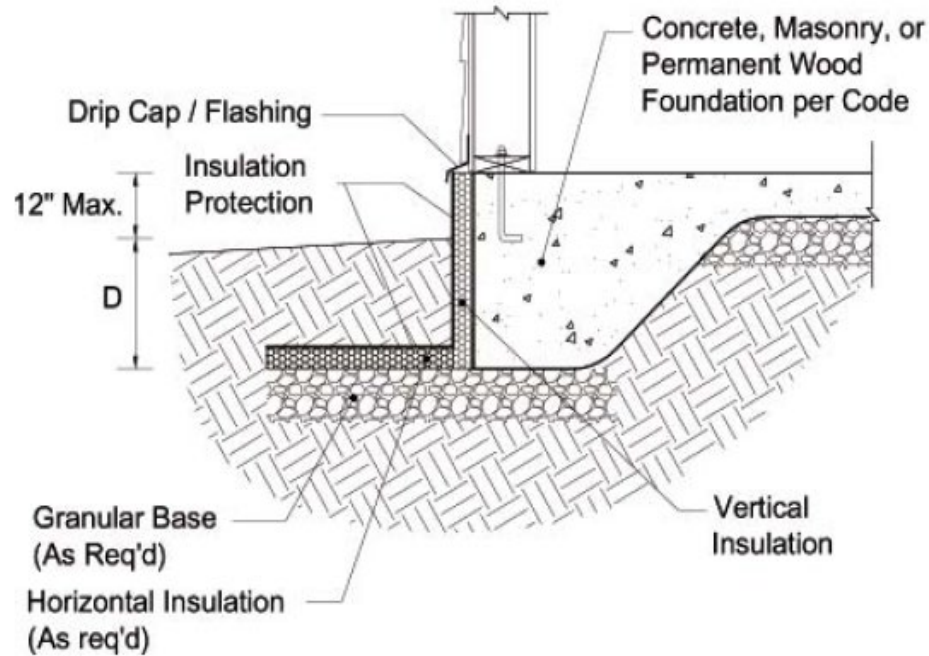

Figure R403.3(1)
Insulation Placement for
Frost-Protected Footings in
Heated Buildings

Example Problem: Lincoln, NE

STEP 3: Details (Foundation Insulation Plan)

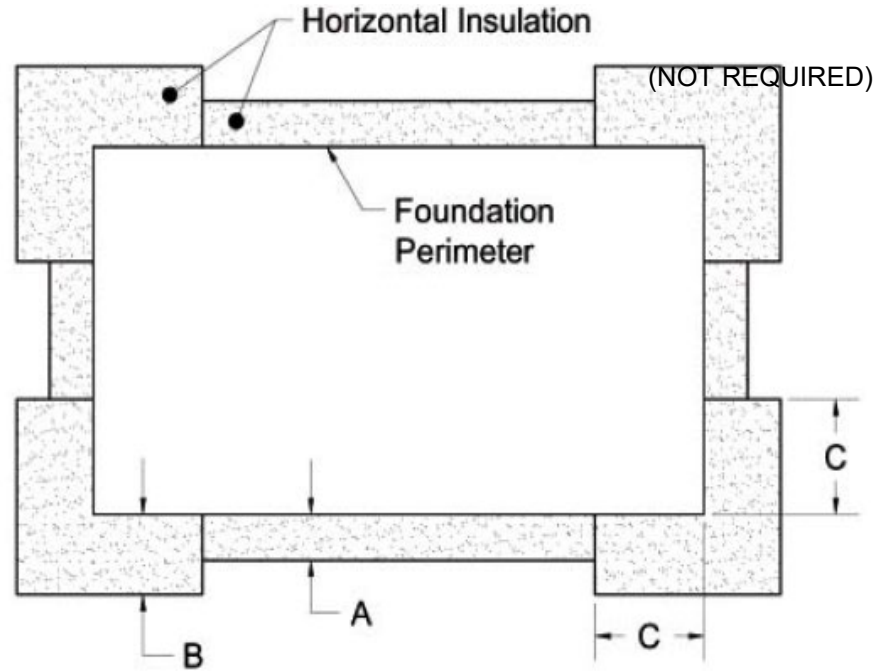

Figure R403.3(1)
Insulation Placement for
Frost-Protected Footings in
Heated Buildings

Special Conditions

- *IRC 403.3.1.1* – Unheated building conventional foundation (e.g., garage) adjoining an FPSF foundation (e.g., house); shows insulation at interface of foundations
- *IRC 403.3.1.2* – FPSF foundation (e.g., addition) adjoining a conventional heated building foundation (e.g., existing house)

Additional Requirements

- Figure R403.3(1) – Vertical insulation must be protected against physical damage and U/V radiation from top of foundation to 6” below grade (various options such as trt’d plywood, elastomeric coatings, stucco, etc.)
- Section R403.3.2 – Horizontal insulation must be protected if less than 12” below grade or when extending outward more than 24”

Additional Requirements

- R403.3.3 – Drainage layer and drain to daylight required under horizontal insulation; slope finish grade to drain away from building
- R403.3.4 – provide termite protection per R320.5*

**Per Section R320.5, foundation wall insulation must be terminated above ground to allow a minimum 6" inspection strip in areas with "heavy" termite infestation probability. This inspection strip is not permitted with FPSF (creates a thermal short circuit). Therefore, recommend using foam impregnated with termiticide in "heavy" areas.*

Verify FPSF Insulation Meets Energy Code

- 2006 IRC Chapter 11, Table N1102.1 **requires R10** slab edge insulation, 2' wide (Climate Zone 5)
- FPSF design for Lincoln, NE requires 1.0" of nominal 5 R/in XPS which gives 1.0" x 5 R/in = 5.0R (or 1.5" EPS x 4.2 R/in = R6.3, nominal) << **R10**
- **Now What?**
 - (1) increase FPSF thickness to meet energy code (or use IECC energy code trade-off), or
 - (2) Use DOE Building Foundation Design Handbook (Table 4-1) to show that using 2' of R5 insulation on the exterior face of the foundation (FPSF design) **saves more energy** than using 2' or R10 insulation placed horizontally under the slab as permitted by the energy code.

Plan Review and Inspection Checklist

- ✓ **Insulation type (per ASTM C578)**
- ✓ **Insulation dimensions and continuity**
- ✓ **Foundation depths**
- ✓ **Distance from top of slab to grade**
- ✓ **Protection of insulation**
- ✓ **Termite precautions**
- ✓ **Drainage**

Overview of ASCE 32

- Provides for three different building use conditions (heated, semi-heated, and unheated)
- Provides insulation requirements for slab on grade, crawlspace, and basement foundations.
- Provides insulation requirements for isolated footings or small unheated areas of otherwise heated buildings
- Allows horizontal (wing) insulation to be reduced in size in trade-off with increasing minimum foundation depth
- Provides guidance for use of non-frost susceptible fills
- Future edition may include a risk-consistent frost depth map for conventional foundations correlated to the AFI map in the IRC and ASCE 32 based on work by Cornell University and NOAA. For example, Lincoln, NE (AFI = 1,500 °F-days) would have a design frost depth of 32" – not very different than current practice of 36" – southern U.S. and seaboard states will be affected more by this change.

...*ASCE 32 is a reference standard in the 2003/2006 IRC and IBC and is applicable to foundation and building types addressed in the IRC and IBC.*

Resources and References

- IRC 2006 (www.iccsafe.org)
- IBC 2006 (www.iccsafe.org)
- Revised Builder's Guide to FPSFs (www.toolbase.org or www.nahb.org)
- Various FPSF research reports and older design guides (www.huduser.org)
- ASCE Standard 32-10 (www.asce.org)

Conclusions

- \$1,000-\$4,000 cost savings per home/business
- \$75/yr energy savings
- Long history of successful performance
- Easy to design
- Easy to build
- Easy to inspect

Any questions?

